



MAZAKA
HEAVY INDUSTRY

MW1000

**PILE DRIVING
MACHINES**



▼ MW1000 PILE DRIVER MACHINE



ENGINE

Make	YANMAR
Model	4TNV88C
Cylinders	4
Displacement L	2.190 cc
Gross Power	47.6 hp (35.5 kW)
Rated Speed	3000 rpm
Certifica	Stage 5
Fuel Tank	60 l
DPF Filter	yes

HAMMER

Operating Pressure	120 bar
Power	1100 joule
Oil Flow	80 l

HYDRAULIC SYSTEM

Oil Flow Rate	50-100 l
Oil Pressure	180 bar
Oil Tank	150 l

TRAVEL SPEED

Low Speed	2 km/h
High Speed	4.4 km/h
Gradeability	20°
Side Walk	10°

DIMENSION

Transport Widht (A1)	2280 mm
Transport Height (A2)	2550 mm
Transport Lenght (A3)	2950 mm
Widht of Machine (A1)	2280 mm
Height of Machine (A4)	4400 mm
Lenght of Machine (A5)	3110 mm
Weight	4350 kg
Mast Height (A6)	4500 mm
Angle of mast forward	12°
Angle of mast backward	-63°

▼ OPTIONAL EQUIPMENT

DTH - Auger - Post Extractor - GPS/GNSS - Remote Control
 Hydromotor System For Ground Screw - Auto Leveling
 Hammer Height Control System - Laser Meter - Stabilizer Cylinder

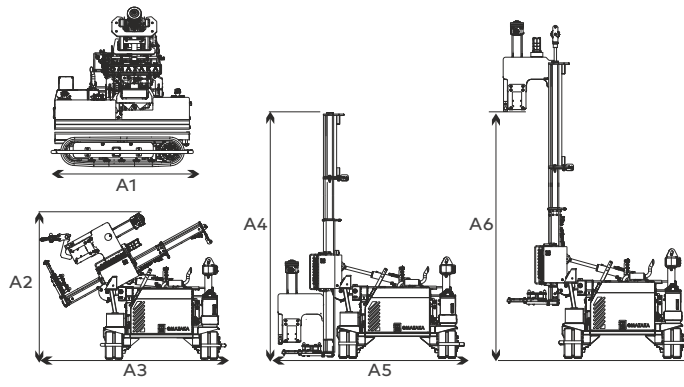

Mazaka Factory

📍 Karpuzsekisi Mah. 2. Cadde
 No: 42 Hacilar-Kayseri/TÜRKİYE
 ☎ +90 352 311 44 18
 ✉ info@mazaka.eu

USA Office

📍 25 Old Kings Hwy N.Ste13
 Darien, CT 06820
 ☎ +1 203 904 8074
 ✉ america@mazaka.eu

Europe Office

📍 Industriestrasse 12-16, 42929
 Wermelskirchen Germany
 ☎ +49 2196 / 729 00 271
 ✉ europe@mazaka.eu

Middle East Office

📍 Ttay Area, Al Khawaneej 2,
 Behind Emirates Road Dubai UAE
 ☎ +90 533 204 41 70
 ✉ dubai@mazaka.eu